

**SL800AC/SL1000AC/
SL1500AC/SL2000AC
Sliding Gate Opener User Manual**

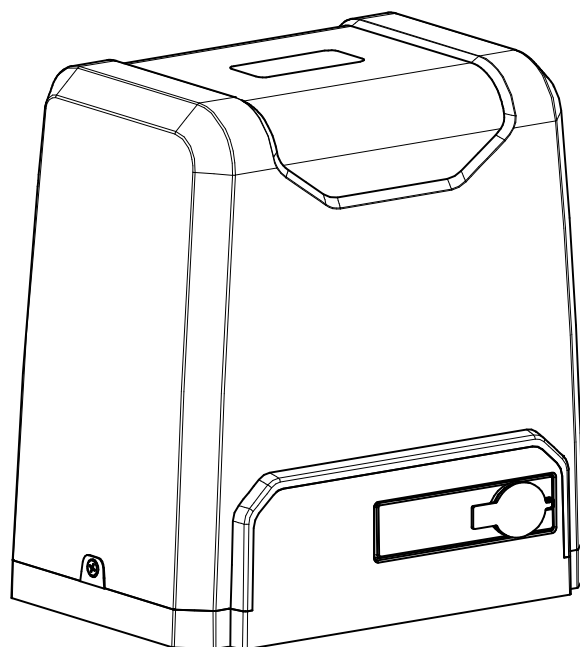

Dear users,

Thank you for choosing this product. Please read this manual carefully before installation and use.

Please do not forget to include this manual if you send the product to a third party.

1. Safety Instruction



Please make sure that the power voltage being used matches with the supply voltage of gate opener (AC110V or AC220V); kids are not allowed to touch the control devices or the remote-control unit.

The remote-control unit is single button mode or three button mode (please refer to the instructions of the remote control in accordance with the actual gate opener type). The indicator light on the remote-control unit will flicker when its button is pressed. Main engine and gate can be unlocked with a disengagement wrench and the gate can be manually operated after disengagement.





Please make sure that nobody is around the main engine or gate when the switch is operated.

Please temporarily stop using the product if the main engine needs to be repaired or regulated. The installation and maintenance of the product must be carried out by professionals.

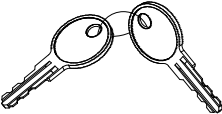
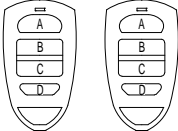

Please read this manual carefully before installing, using, maintaining or repairing it. Without following this manual, any injury or property losses caused by improper use or unauthorized modification is out of the responsibility of our company.

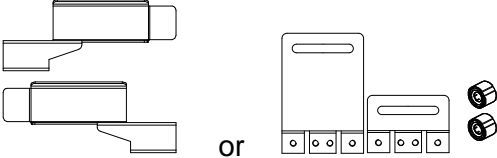
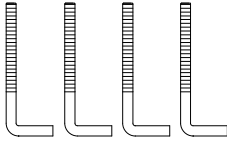
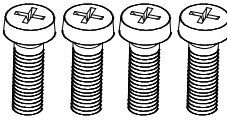
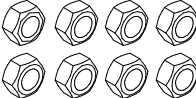
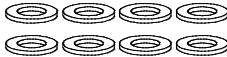
2. Packing List (standard)

No.	Picture	Name	Quantity
1		Main engine	1
2		Manual release key	2
3		Remote control	2
4		Spring limit switch accessories box / Magnetic limit switch accessories box	1
4-1		Spring limit switch block / Magnetic limit switch block	1
4-2		Foundation bolt M10	4
4-3		Spring limit switch block mounting screw M6X10 / Magnetic limit switch block mounting screw M6X18	4
4-4		Nut M10	8
4-5		Flat washer Ø10	8
4-6		Spring washer Ø10	4

2. Packing List (optional)

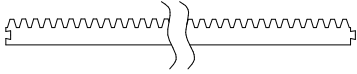
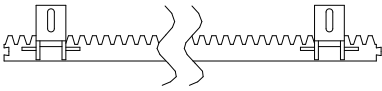
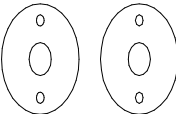
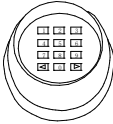
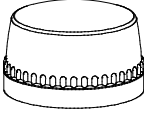
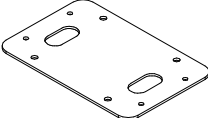
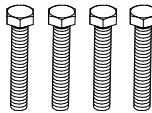
No.	Picture	Name	Quantity
1		Steel gear rack	1m/pc
2		Nylon gear rack	1m/pc
3		Infrared sensor	1
4		Wireless keypad	1
5		Alarm lamp	1
6		Mounting plate	1
7		Hexagon head bolt M10x60	4

3. Technical parameters

Model	SL800AC	SL1000AC	SL1500AC	SL2000AC
Power supply	220V/50Hz;110V/60Hz			
Motor power	370W	400W	550W	750W
Gate moving speed	11-13m/min			
Maximum weight of gate	800kg	1000kg	1500kg	2000kg
Remote control distance	≥30m			
Remote control mode	Single button mode / Three button mode			
Limit switch	Spring limit switch / Magnetic limit switch			
Noise	≤60dB			
Working duty	S2, 20min			
Recording of up remote controls	25			
Frequency	433.92 MHz			

Working temperature	-20°C ~ +70°C			
Package weight	14kg	15kg	16kg	17kg

4. Installation

SL800AC/SL1000AC/SL1500AC/SL2000AC sliding gate opener is applicable to gate weight less than 800kg/1000kg/1500kg/2000kg, and length of the sliding gate less than 12m. The drive mode adopts the rack and gear transmission. This gate opener must be installed inside the enclosure or yard for protection.

4.1 Installation drawing

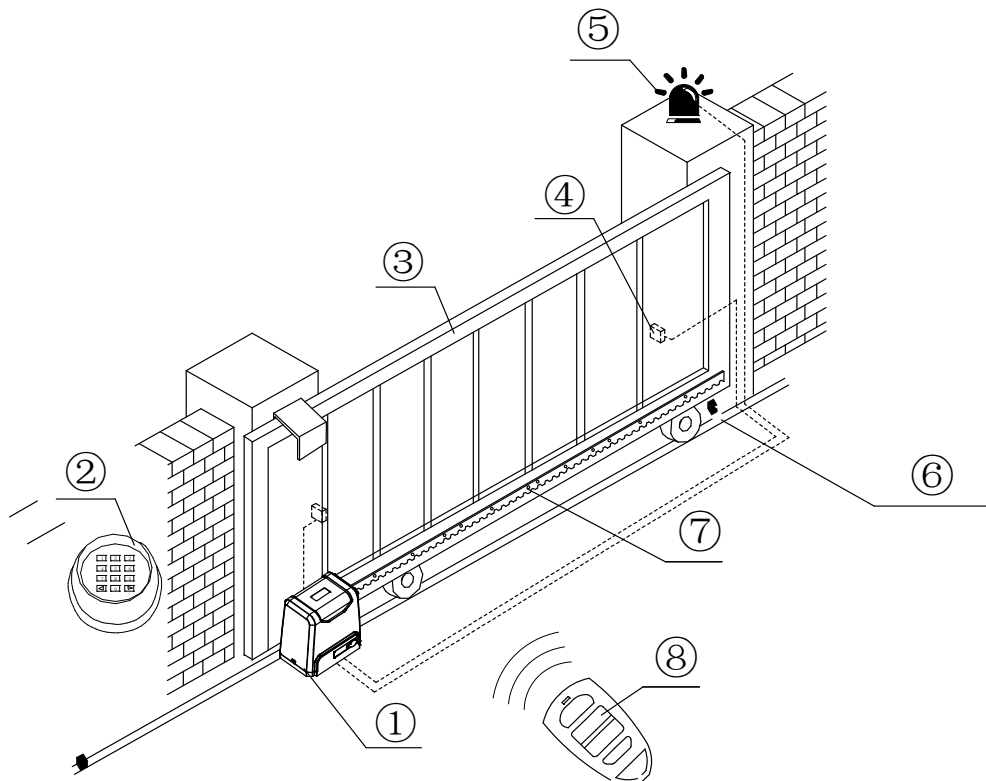

Figure 1

- ① Gate opener; ② Wireless keypad (optional); ③ Gate; ④ Infrared sensor (optional);
 ⑤ Alarm lamp (optional); ⑥ Safety stop block; ⑦ Gear rack; ⑧ Remote control;

4.2 Size of main engine and accessories

4.2.1 Size of main engine

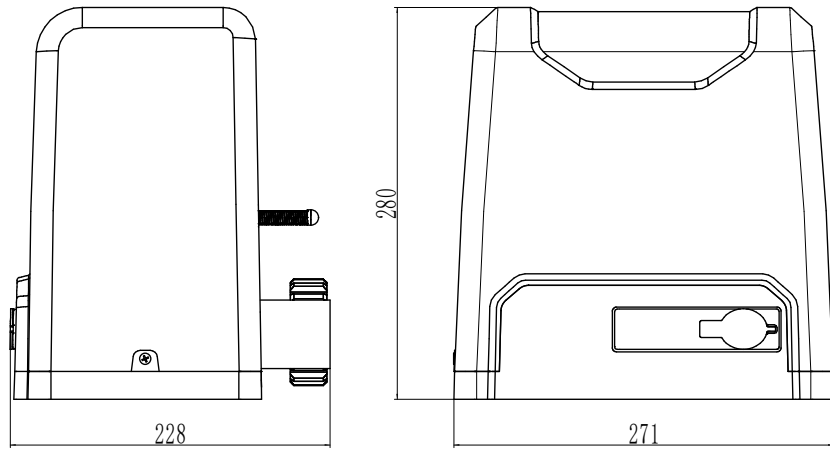

Figure 2

4.2.2 Size of mounting plate

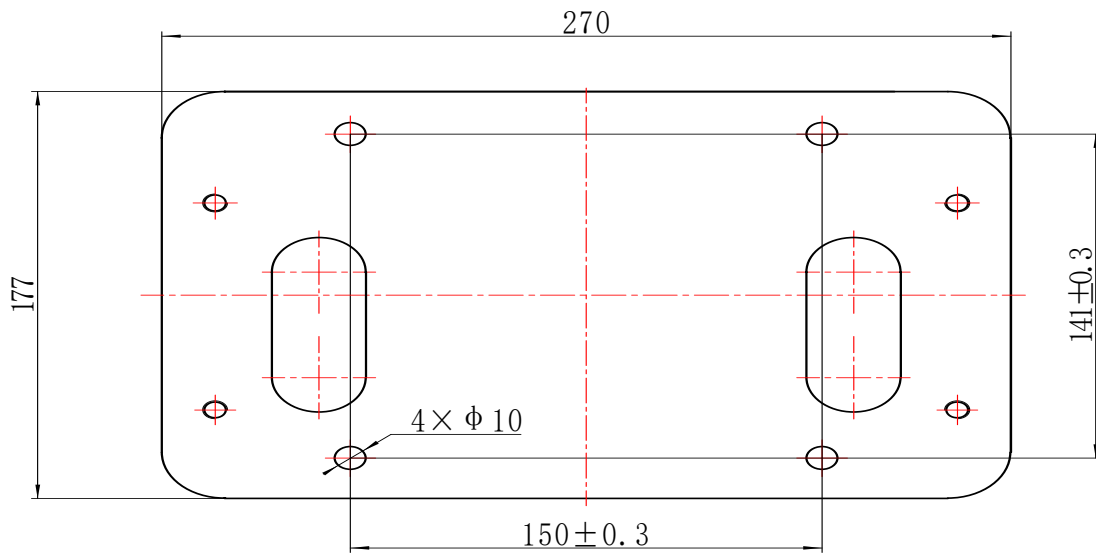

Figure 3

4.3 Installation procedures

4.3.1 Preparation work before installation

Please make sure that the sliding gate is correctly installed, the gate rail is horizontal, and the gate can be manually moved smoothly before installing the gate opener.

Cable installation

In order to guarantee the normal operation of the gate opener and protect the cables from damages, please bury the motor & power cable and controlling cable separately with two PVC tubes.

Concrete pedestal

Please precast a concrete pedestal with the size can be 500mm x 300mm, depth be 250mm in advance, so as to firmly install SL800AC/SL1000AC/SL1500AC/SL2000AC gate opener. **Please make sure the distance between the gate and gate opener is appropriate before casting the pedestal.**

Embedded screws

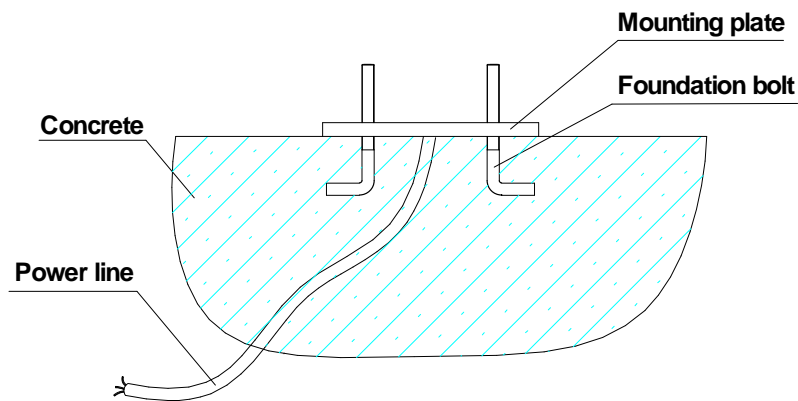

Figure 4

4.3.2 Main engine installation

- Dismantle the plastic housing on the main engine before installation and keep the relevant fasteners properly;
- Please prepare the power line for connecting the mounting plate to the main engine (the number of power supply cable cores should not be less than 3 PCS, the sectional area of cable core should be over 1.5mm² and the length should be determined by users according to the situation on installation spot)
- Please unlock the main engine before installation, the unlock method is: remove the rubber key cover, insert the key, and open the manual release bar till it rotates by 90° as shown in Figure 5. Then turn the output gear and the gear can be rotated easily;

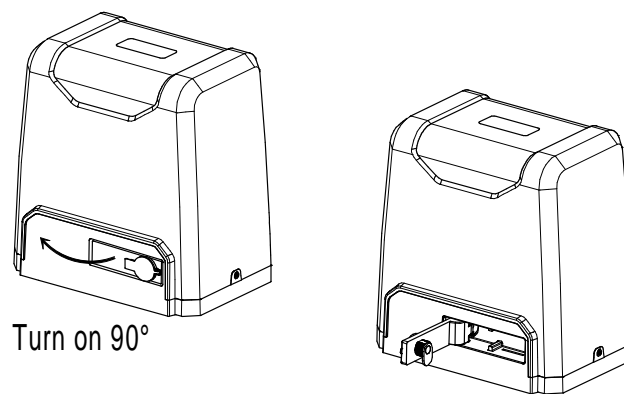

Figure 5

4.3.3 Gear rack installation

- Fix the mounting screws to the rack.
- Put the rack on the output gear; make the rack engage with the output gear then weld the mounting screws to the gate (each screw with one solder joints firstly).
- Manually move the gate (gate should be moved smoothly after motor unlocked) to check whether there is a fit clearance between rack and output gear, as shown in Figure 7.
- Weld all the mounting screws to the gate firmly.

- Make sure that all racks on the same straight line.
- Pull the gate after installed, make sure the entire trip is flexible without any stuck.

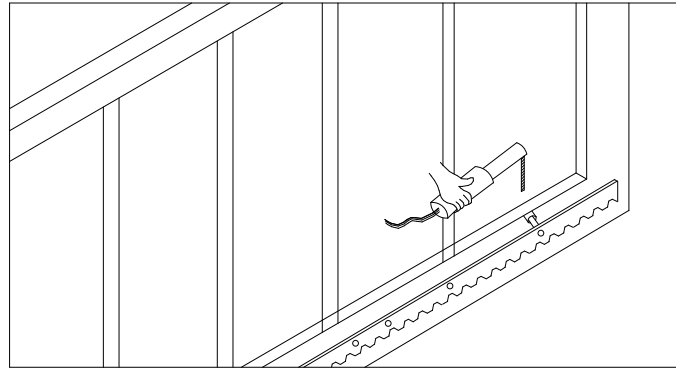

Figure 6

The fit clearance of output gear and rack is shown in Figure 7 below:

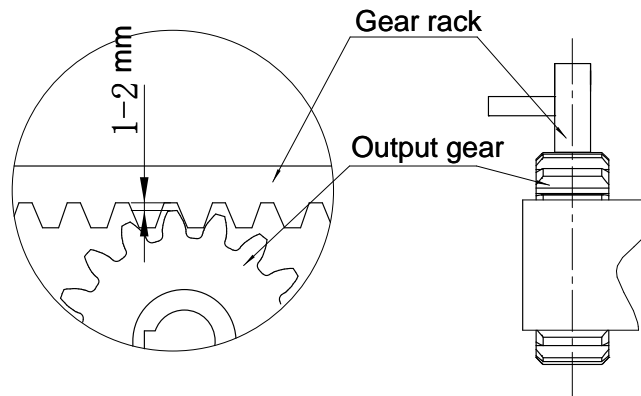

Figure 7



Warnings

- To ensure safety, install safety stop blocks on both ends of the rail to prevent the gate from running out of the rail. Before installing the main engine, make sure that the safety stop blocks are in place and whether it has the function of preventing the gate from running out of the rail or safety range.
- Please make sure that the main engine and its components have good mechanical properties, and the gate can be operated flexibly when manually moved before installing the main engine.
- Please note that for this product, one control can only drive one main engine, otherwise, the control system will be damaged.
- Earth leakage circuit breaker must be installed in where the gate movement can be seen, and the minimum mounting height is 1.5m to avoid being touched by children.
- After installation, please check whether the mechanical property is good or not, whether gate movement after manual unlocking is flexible or not, whether the installation for infrared sensor (optional) is correct and effective.

4.3.4 Limit switch adjustment

Spring limit switch - The installation position of spring limit switch is shown in Figure 8:

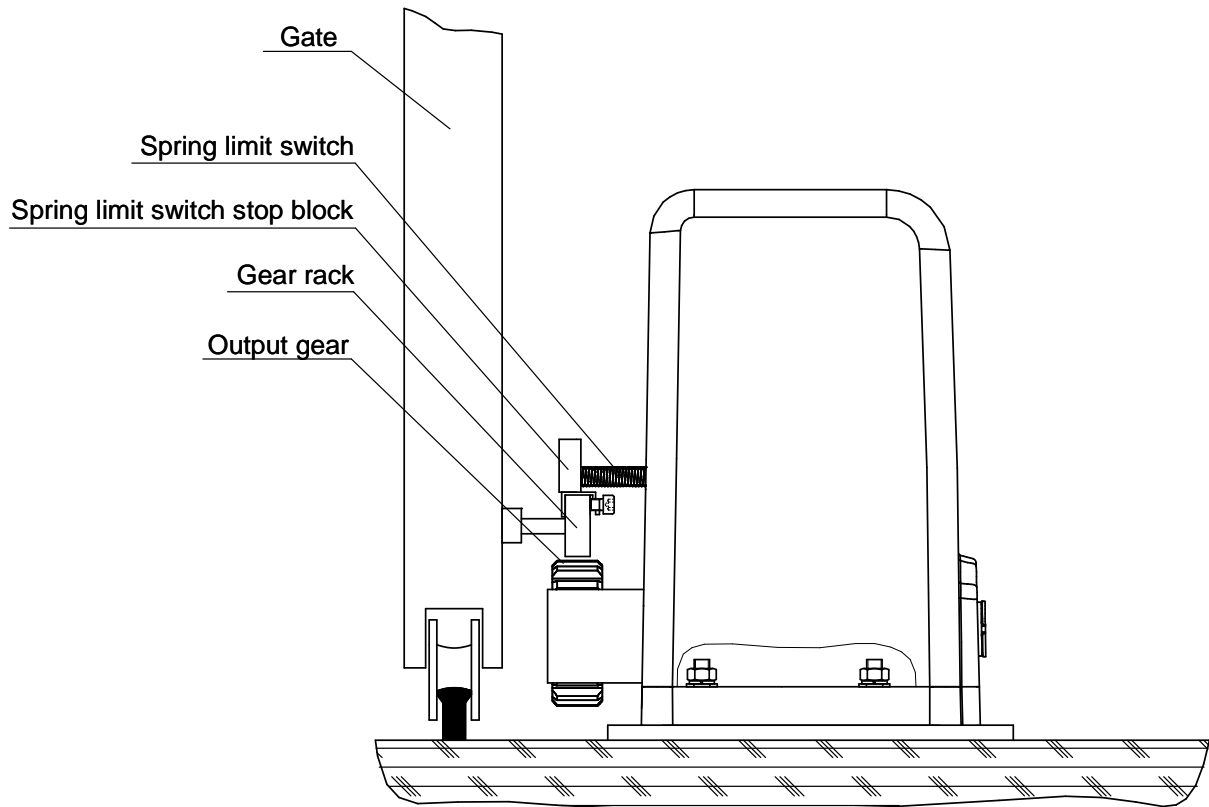

Figure 8

The installation of spring limit switch stop block is shown in Figure 9:

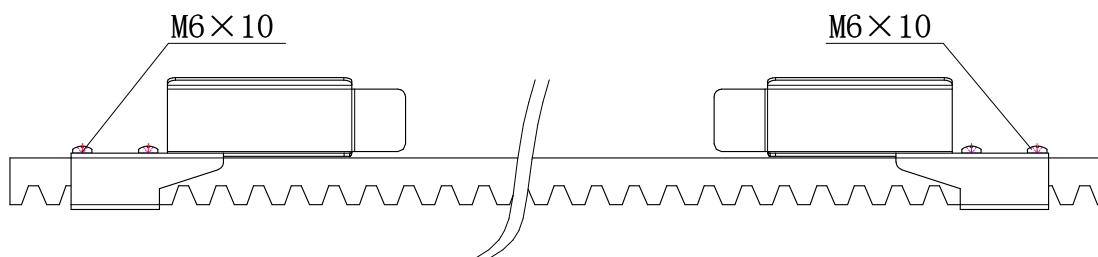

Figure 9

Magnetic limit switch - The installation position of magnetic limit switch is shown in Figure 10:

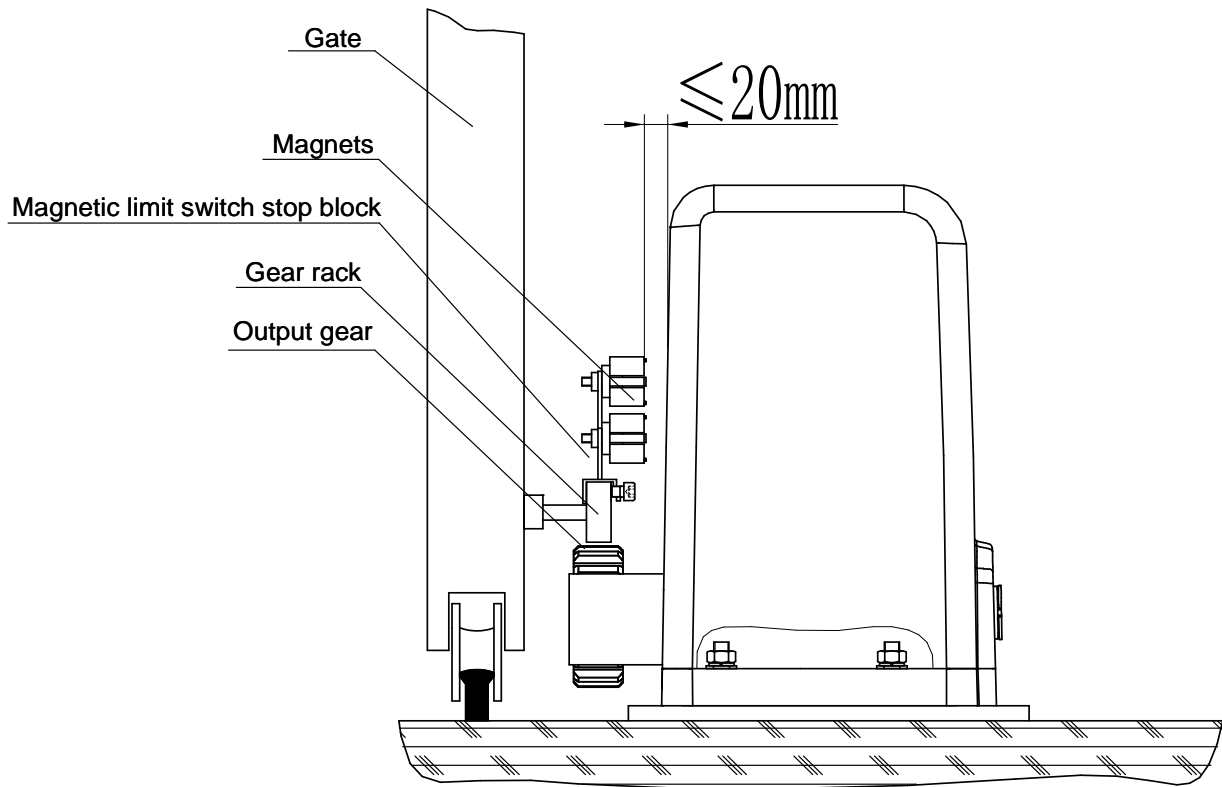

Figure 10

The installation of magnetic limit switch stop block is shown in Figure 11:

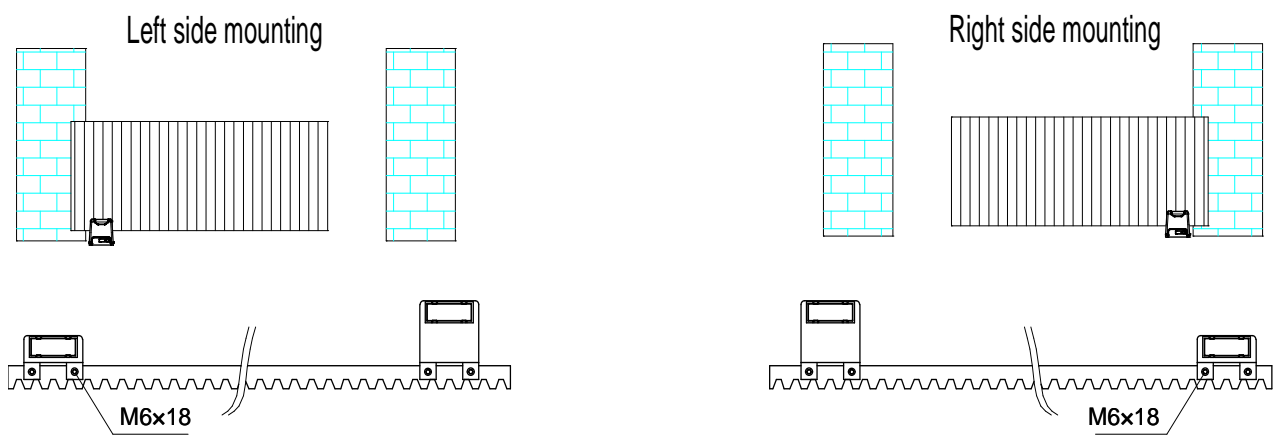

Figure 11

Note: The default setting is right side mounting. (According to actual situation, please refer to the “Note” of section 4.3.5.1 and 4.3.5.2 “Adjustment and operation” to adjust.)

5. Others

5.1 Maintenance

Check whether the gate operates normally every month.

For the sake of safety, each gate is suggested to be equipped with infrared protector, and regular inspection is required.

Before installation and operation of the gate opener, please read all instructions carefully.

Our company reserves the right to change the instruction without prior notice.

5.2 Troubleshooting

Problems	Possible Reasons	Solutions
The gate cannot open or close normally, and LED does not light.	<ol style="list-style-type: none">1.The power is off.2.Fuse is burned.3.Control board power wiring with problem.	<ol style="list-style-type: none">1.Switch on the power supply.2.Check the fuse (code FU), change the fuse if burnt.3.Re wiring according to instructions.
The gate can open but cannot close.	<ol style="list-style-type: none">1.Photocell wiring with problem.2.Photocell mounting with problem.3.Photocell is blocked by objects.4.Sensitivity of obstacle is too high (Intelligent type).5.Hall switch parts is damaged (Intelligent type).	<ol style="list-style-type: none">1.If not connect photocell, please make sure that the infrared port and GND short circuit; if connect infrared sensor, please make sure the wiring is correct and the photocell is N.C.2.Make sure that the photocell mounting position can be mutually aligned.3.Remove the obstacle.4.Reduce the sensitivity of obstacle.5.Change hall switch parts.
Remote control doesn't work.	<ol style="list-style-type: none">1.Battery level of the remote control is low.2.Remote control learning is not completed.	<ol style="list-style-type: none">1.Change the remote control battery.2.Re-conduct remote control learning.
Press OPEN, CLOSE button, the gate is not moving, motor has noise.	<ol style="list-style-type: none">1.Capacitor is broken.2.Capacitor is poor connected.3.Gate moving is not smoothly.	<ol style="list-style-type: none">1.Change capacitor.2.Check the capacitor wiring.3.According to the actual situation to adjust the motor or the gate.
Not stop at the limit position when opening / closing.	<ol style="list-style-type: none">1. The limit direction is wrong.2. The mounting of magnetic limit switch with problem.	<ol style="list-style-type: none">1.Check whether the limit switch wiring is consistent with the actual direction of

		operation. 2. Check whether the distance between magnetic limit switch and motor, and the height of the magnetic limit switch can reach up the mounting requirement.
Leakage switch tripped.	Power supply line short circuit or motor line short circuit.	Check wiring.
Remote control working distance is too short.	Signal is blocked.	Connect external receiver antenna, 1.5 meters above ground.
The gate moves to the middle position to stop or reverse.	1.Motor output force is not enough (Intelligent type). 2.Sensitivity of obstacle is too big (Intelligent type). 3.Gate meets obstacle.	1.Adjust the VR4. 2.Adjust the VR1. 3.Remove the obstacle.
Gate opens automatically	Automatic close function has been turned on but with incorrect opening direction.	Please refer to the attentions under 4.3.5.1 and 4.3.5.2 to change the opening direction.

Warranty

Warranty Ordinance

1. To repair against this warranty card and invoice during the warranty period.
2. Warranty period: 1 year after the date of invoice.
3. Without unauthorized dismantling, any product broken or damage due to quality problem, we'll offer the repair service for free or replace for free.
4. The malfunction and damaged caused by incorrect use or man fault is not covered by this warranty.

Maintenance Record

Check Date	Check Content	Maintained by